

# OVEN - Smeg SA995X

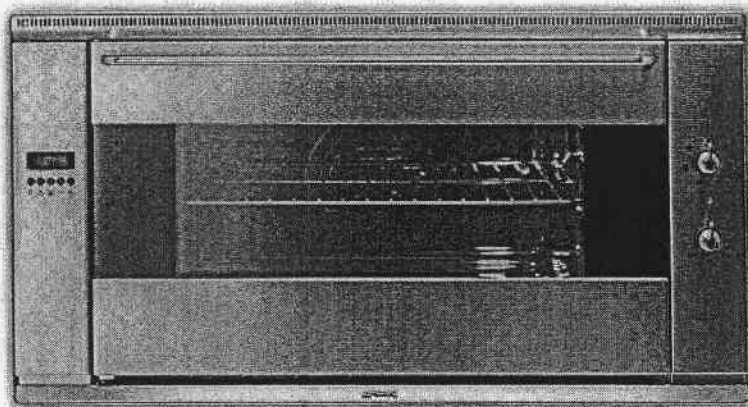

installation  
and operating  
instructions



SA995XR  
oven

GB-IE

## Introduction

### 1. INSTRUCTIONS FOR SAFE AND PROPER USE



THIS MANUAL IS AN INTEGRAL PART OF THE APPLIANCE AND THEREFORE MUST BE KEPT IN ITS ENTIRETY AND IN AN ACCESSIBLE PLACE FOR THE WHOLE WORKING LIFE OF THE OVEN. WE ADVISE CAREFUL READING OF THIS MANUAL AND ALL THE INSTRUCTIONS THEREIN BEFORE USING THE OVEN. INSTALLATION MUST BE CARRIED OUT BY QUALIFIED PERSONNEL IN ACCORDANCE WITH THE REGULATIONS IN FORCE. THIS APPLIANCE IS INTENDED FOR DOMESTIC USES AND CONFORMS TO CURRENT **REGULATIONS IN FORCE**. THE APPLIANCE HAS BEEN BUILT TO CARRY OUT THE FOLLOWING FUNCTIONS: **COOKING AND HEATING-UP OF FOOD**. ALL OTHER USES ARE CONSIDERED IMPROPER.

**THE MANUFACTURER DECLINES ALL RESPONSIBILITY FOR IMPROPER USE.**

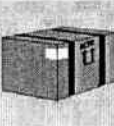

DO NOT LEAVE THE PACKING IN THE HOME ENVIRONMENT. SEPARATE THE VARIOUS WASTE MATERIALS AND TAKE THEM TO THE NEAREST SPECIAL GARBAGE COLLECTION CENTRE.

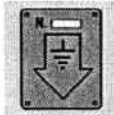

IT IS OBLIGATORY FOR THE ELECTRICAL SYSTEM TO BE GROUNDED ACCORDING TO THE METHODS REQUIRED BY SAFETY RULES.

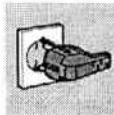

WHEN LINKING UP TO MAINS BY PLUG AND SOCKET, MAKE SURE THAT BOTH ARE COMPATIBLE AND CONNECT BY MEANS OF A POWER CABLE COMPLYING WITH APPLICABLE REGULATIONS.

THE SOCKET MUST BE ACCESSIBLE AFTER THE APPLIANCE HAS BEEN BUILT IN.

**NEVER UNPLUG BY PULLING ON THE CABLE.**



DO NOT OBSTRUCT VENTILATION OPENINGS AND HEAT DISPERSAL SLITS.



IMMEDIATELY AFTER INSTALLATION CARRY OUT A BRIEF INSPECTION TEST OF THE OVEN, FOLLOWING THE INSTRUCTIONS BELOW. SHOULD THE APPLIANCE NOT FUNCTION, DISCONNECT IT FROM THE SUPPLY AND CALL THE NEAREST TECHNICAL ASSISTANCE CENTRE.

**NEVER ATTEMPT TO REPAIR THE APPLIANCE.**

## Introduction

GB-IE



ALWAYS CHECK THAT THE CONTROL KNOBS ARE IN THE "ZERO" (OFF) POSITION WHEN YOU FINISH USING THE OVEN.

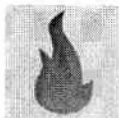

NEVER PUT INFLAMMABLE OBJECTS IN THE OVEN: THEY COULD BE ACCIDENTALLY LIGHTED AND CAUSE FIRES.



DURING USE THE APPLIANCE BECOMES VERY HOT. TAKE CARE NOT TO TOUCH THE HEATING ELEMENTS INSIDE THE OVEN.

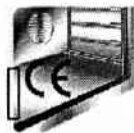

THE I.D. PLATE WITH TECHNICAL DATA, REGISTRATION NUMBER AND BRAND NAME IS POSITIONED VISIBLY ON THE OVEN DOOR FRAME. THE PLATE **MUST NOT BE REMOVED**.



**THE OVEN IS DESIGNED FOR USE BY ADULTS.** DO NOT ALLOW CHILDREN TO GO NEAR OR PLAY WITH IT.



REPLACED APPLIANCES MUST BE TAKEN TO A SPECIAL GARBAGE COLLECTION CENTRE.



**The manufacturer declines all responsibility** for damage to persons or things caused by non-observance of the above prescriptions or by interference with any part of the appliance or by the use of non-original spares.

GB-IE

# Instructions for the user

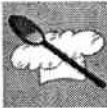

## 3. DESCRIPTION OF CONTROLS

### 3.1 Front control panel



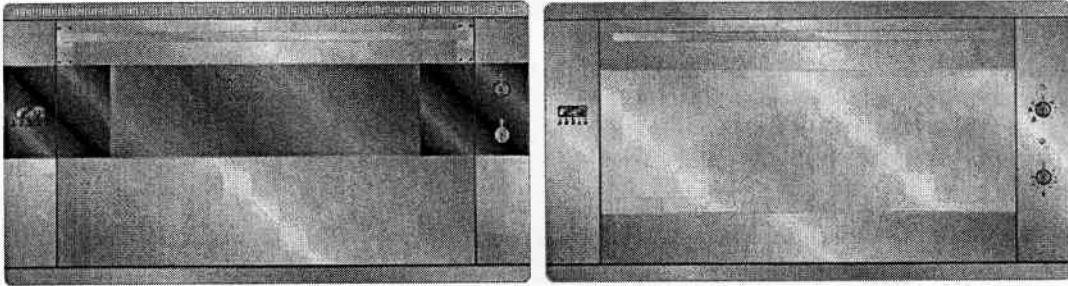





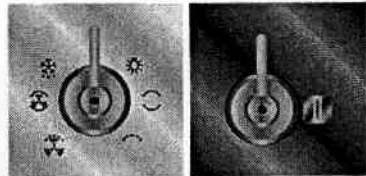













All the oven controls are grouped together on the front panel.



#### FUNCTION SWITCH KNOB

Rotate the knob in either direction to select desired function from the following:



- |   |   |                                  |   |   |  |
|---|---|----------------------------------|---|---|--|
|  |  | NO FUNCTION SET                  |  |  | UPPER AND LOWER HEATING ELEMENT + VENTILATION      |
|  |  | OVEN LIGHT                       |  |  | VENTILATED HEATING ELEMENT + VENTILATION           |
|  |  | UPPER AND LOWER HEATING ELEMENT  |  |  | LOWER HEATING ELEMENT + VENTILATED HEATING ELEMENT |
|  |  | WIDE GRILL ELEMENT               |  |  | LOWER HEATING ELEMENT + VENTILATION                |
|  |  | GRILL ELEMENT                    |  |  | DEFROSTING   |
|  |  | WIDE GRILL ELEMENT + VENTILATION |   |   |  |



## Instructions for the user

GB-IE

### THERMOSTAT KNOB

Cooking temperature is selected by turning the knob clockwise to the desired setting, between 50° and 250°C.

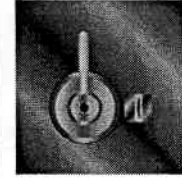
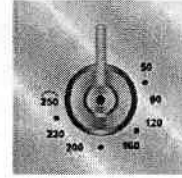

### THERMOSTAT INDICATOR LIGHT



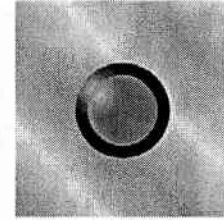

When this light comes on, the oven is heating up.  
 When this light goes out, the preset heating temperature has been reached.  
 When the light flashes, the temperature inside the oven is steady at the set temperature.

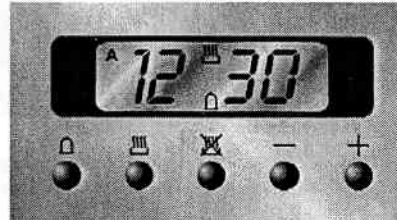



*The programmer user instructions are valid only for the **main oven**.*



### LIST OF FUNCTIONS

-  MINUTE-COUNTER KEY
-  COOKING TIME KEY
-  END-OF-COOKING KEY
-  DECREASE TIME KEY
-  INCREASE TIME KEY

#### 3.2.1 Clock adjustment

When using the oven for the first time, or after a power failure, the display flashes regularly and indicates **0:00**. Press the keys   and at the same time the keys **+** or **-**: each single press changes the time by 1 minute either up or down.



*Before setting the programmer activate the desired function and temperature.*









## Instructions for the user

GB-IE

### 3.2.2 Semiautomatic cooking

Use this setting for automatic oven switch-off at the end of cooking time.



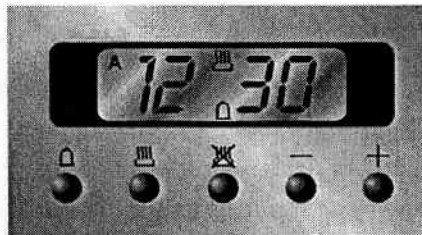

By pressing key , the display lights up, showing ; keep the key pressed and at the same time, press keys  or  to set the cooking time.



Release key  to start the programmed cooking time count. The display will now show the right time together with symbols A and .





### 3.2.3 Automatic cooking



Use this setting to automatically start and stop the oven.

By pressing key , the display lights up showing ; keep the key pressed and at the same time, press keys  or  to set the cooking time.

By pressing key , the sum of the right time + cooking time will appear; keep the key pressed and at the same time, press keys  or  to regulate the end of cooking time.

Release key  to start the programmed count and the display will show the right time together with symbols A and .



*After set-up, to see the cooking time remaining, press the key ; to see the end of cooking time press the key .*

*Set-up with incoherent values is logically prevented (e.g. the contrast between a cooking time and a longer period will not be accepted by the programmer).*

### 3.2.4 End of cooking

When cooking is over, the oven will automatically switch off and, at the same time, an intermittent alarm will sound. After switching off the alarm, the display will once again show the right time together with the symbol , indicating that the oven has returned to manual operation mode.

GB-IE

## Instructions for the user





### 3.2.5 Adjusting alarm volume

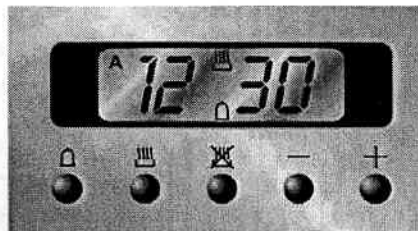





The acoustic alarm has three different settings. These can be operated, while the alarm is sounding, by pressing key .



### 3.2.6 Switching off the alarm

The alarm switches off automatically after seven minutes. They can be manually de-activated by pressing the keys  and  together.



### 3.2.7 Minute Counter

The programmer can also be used as a simple minute counter. By pressing key , the display shows ; keep the key pressed and at the same time press keys  or . On releasing the key , programmed counting will begin and the display will show the current time and the symbol .





*After set-up, to see the remaining time, press the key . Use as a minute counter does not interrupt functioning of the oven at the end of the programmed time.*

### 3.2.8 Cancellation of set data

Once the programme has been set, keep the key of the function to be cancelled pressed, while at the same time  is reached by means of variation keys  or . Time cancellation will be considered as end-of-cooking time by the programmer.

### 3.2.9 Changing the set data

The cooking data entered can be changed at any time by keeping the function key pressed and at the same time adjusting the keys  or .



## Instructions for the user

GB-IE

### 4. USE OF THE OVEN



Make sure that you have either turned the minute minder knob to the  symbol or set a cooking time. If the timer knob is on 0, no heating elements will come on.

#### 4.1 Warnings and general advice

Before using the oven for the first time, pre-heat it to maximum temperature (250°C) long enough to burn any manufacturing oily residues which could give the food a bad taste.



During cooking, do not cover the bottom of the oven with aluminium or tin foil and do not place pans or oven trays on it as this may damage the enamel coating. If you wish to use greaseproof paper, place it so that it will not interfere with the hot air circulation inside the oven.



To prevent any steam in the oven creating problems, open the door in two stages: half open (5 cm approx.) for 4-5 seconds and then fully open. To access food, always leave the door open as short a time as possible to prevent the temperature in the oven from falling and ruining the food.

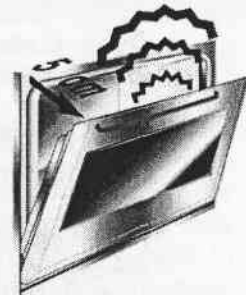

#### 4.2 Cooling system

The oven is equipped with a cooling system which automatically comes on upon the oven being turned on.

Fans cause a steady outflow of air from above the door which may continue for a brief period of time even after the oven has been turned off.

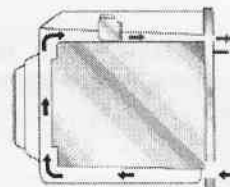

#### 4.3 Oven light

To turn on the oven light in models with static oven, rotate the temperature knob clockwise to the first setting aligned with the lamp symbol (). The light will remain on throughout entire oven operation.



GB-IE

## Instructions for the user



### 5. AVAILABLE ACCESSORIES

The oven features **4 support** positions for plates and racks of different height.

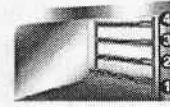

*Some models do not feature all accessories.*

**Grill:** useful for holding cooking vessels.



**Plate grill:** for placing above plate for cooking foods that might drip.

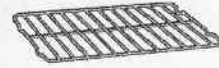

**Oven plate:** useful for catching fat from foods on the grill above.



**Pastry plate:** for baking cakes, pizza and oven desserts.



**Roasting spit:** useful for cooking chicken, sausages and anything else requiring uniform cooking over the whole surface. Only for **auxiliary oven**.

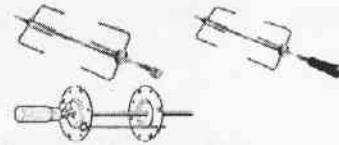

**Main oven rotisserie frame:** to be fitted into the holes provided in the oven dish.



#### **Accessories available on request**

*Original accessories may be ordered from any Authorised Service Centre.*



## Instructions for the user

GB-IE

### 6. COOKING HINTS



*In fan-assisted mode preheating should be carried out at 30/40°C above the cooking temperature. This considerably shortens cooking times and reduces power consumption, as well as giving better cooking results.*



**Keep the oven door closed during cooking**

#### 6.1 Traditional cooking (multifunction models)



FUNCTION SWITCH



THERMOSTAT SWITCH

50 ÷ 250°C



This traditional cooking method, in which heat comes from above and below, is suitable for cooking food on a single level. You have to pre-heat the oven until the set temperature is reached. Place the food in the oven only after the thermostat indicator light has turned off. very fatty meats may be put in when the oven is still cold. Put frozen meat in immediately, without waiting for it to thaw. The only precaution you need to take is to set the temperature about 20°C lower and cooking time about 1/4 longer than you would for fresh meat.

#### 6.2 Hot-air cooking (multifunction models)



FUNCTION SWITCH



THERMOSTAT SWITCH

50 ÷ 250°C



This system is suitable for cooking on several levels, including different types of food (fish, meat etc.), without the tastes and smells mingling. Air circulation in the oven ensures a uniform distribution of heat. Pre-heating is not necessary.

GB-IE

## Instructions for the user



Multiple cooking is possible as long as the cooking temperature of the different foods is the same.

### 6.3 Grill cooking

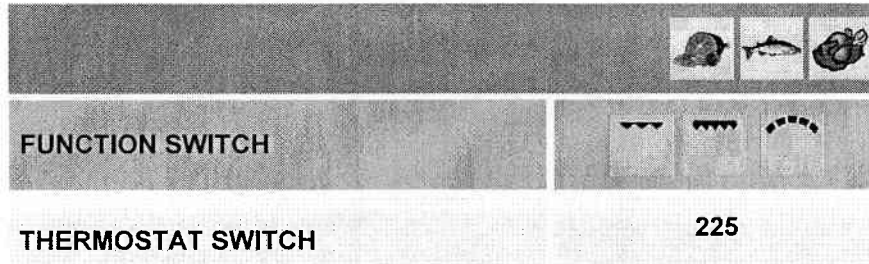

Permits rapid browning of foods. You are advised to place the pan in the highest guide. For short-term cooking of small quantities, place the grid in the fourth guide from the bottom. For long-term cooking and grills, put the grid in the lowest guide in accordance with the size of the pieces.

### 6.4 Hot-air grilling (multifunction models)

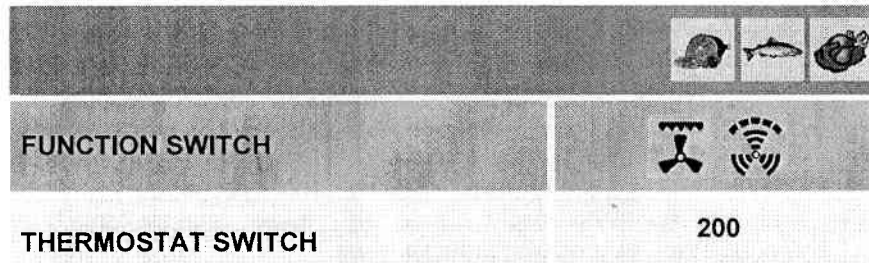

Ensures uniform heat distribution with greater heat penetration into the food. Food will be lightly browned on the outside and remain soft inside. **Keep the oven door closed during cooking. Heating up time must not exceed 60 minutes.**

### 6.5 Defrosting (multifunction models)

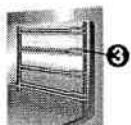
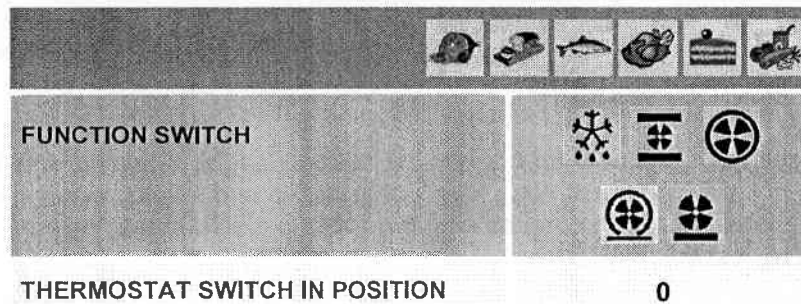

The flow of air produced by the fan ensures quicker defrosting. The air circulating inside the oven is at room temperature.



The advantage of defrosting at room temperature is that it does not alter the taste and appearance of the food.

GB-IE

# Instructions for the user



## 6.6 Spit roasting (models with static oven)

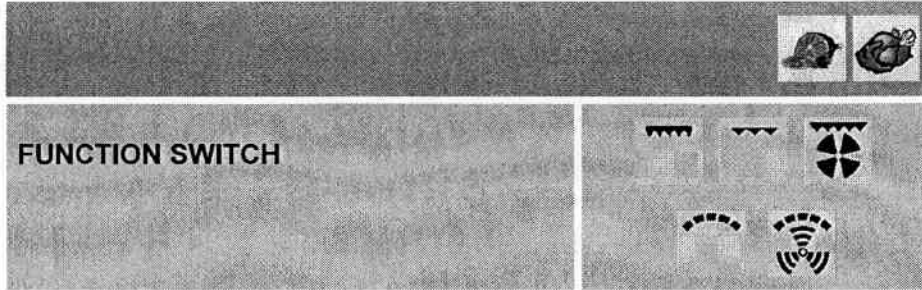

THERMOSTAT SWITCH IN POSITION

200

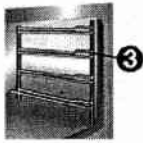

Prepare the spit with the food, blocking fork screws **A**. Insert frame **B** into the third guide from the bottom. Remove handle **D** and position the spit shaft so that pulley **E** is guided on the link of frame **B** in the right side. Insert the drip tray into the oven as far as it will go until the tip of the rod is in line with the hole **C**. Now rock the frames **B** to insert the tip of the rod into the drive connection **C** of the rotisserie motor on the side of the oven. Pour a bit of water into the pan to avoid smoke from the dripping.



*It is normal for the thermostat light to flash during cooking. This indicates the temperature inside the oven is regular.*

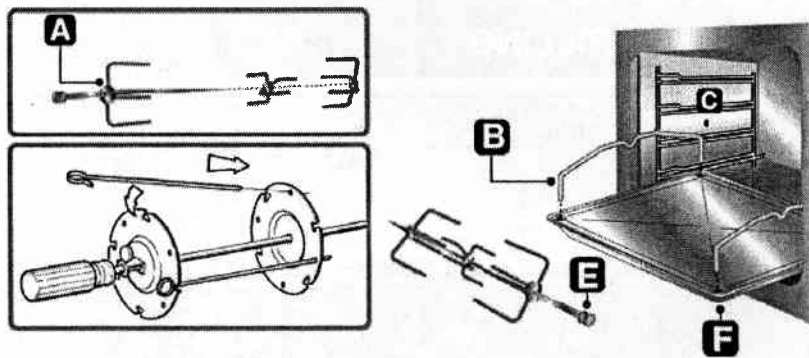

**CAUTION:** the frames **B** must be fitted as shown in the diagram





# Instructions for the user

GB-IE

## 6.7 Recommended cooking table

Cooking times, especially meat, vary according to the thickness and quality of the food and to consumer taste.

### TRADITIONAL COOKING

|                      | LEVEL FROM BELOW | TEMPERATURE (°C) | TIME IN MINUTES (*)     |
|----------------------|------------------|------------------|-------------------------|
| <b>FIRST COURSES</b> |                  |                  |                         |
| OVEN-BAKED PASTA     | 2                | 200              | 30-35                   |
| <b>MEAT</b>          |                  |                  |                         |
| ROAST VEAL           | 2                | 200              | 60-65                   |
| ROAST PORK           | 2                | 225              | 70-75                   |
| CHICKEN              | 2                | 200              | 60-65                   |
| DUCK                 | 2                | 200              | 120-125                 |
| RABBIT               | 2                | 200              | 90-95                   |
| FISH                 | 2                | 200              | ACCORDING TO DIMENSIONS |
| PIZZA                | 2                | 250              | 15-20                   |
| <b>DESSERTS</b>      |                  |                  |                         |
| MERINGUES            | 2                | 125              | 55-60                   |
| BISCUITS             | 2                | 200              | 20-25                   |
| PASTRY               | 1                | 200              | 25-30                   |
| SPONGE CAKE          | 2                | 175              | 35-45                   |
| FRUIT PIE            | 1                | 200              | 30-35                   |

(\*) = WITH PREHEATED OVEN

### GRILLING

|                        | LEVEL FROM BELOW | TIME IN MINUTES |                |
|------------------------|------------------|-----------------|----------------|
|                        |                  | FIRST SURFACE   | SECOND SURFACE |
| TOAST                  | 3                | 5               | 5              |
| CHICKEN                | 3                | 30              | 30             |
| FISH                   | 3                | 18              | 18             |
| TOMATOES OR COURGETTES | 3                | 8               | 8              |

### HOT-AIR COOKING

|                      | LEVEL FROM BELOW | TEMPERATURE (°C) | TIME IN MINUTES         |
|----------------------|------------------|------------------|-------------------------|
| <b>FIRST COURSES</b> |                  |                  |                         |
| OVEN-BAKED PASTA     | 2                | 175              | 30-35                   |
| <b>MEAT</b>          |                  |                  |                         |
| ROAST VEAL           | 2                | 175              | 60-65                   |
| ROAST PORK           | 2                | 200              | 70-75                   |
| CHICKEN              | 2                | 200              | 60-65                   |
| DUCK                 | 2                | 175              | 120-125                 |
| RABBIT               | 2                | 175              | 90-95                   |
| FISH                 | 2                | 175              | ACCORDING TO DIMENSIONS |
| PIZZA                | 2                | 225              | 15-20                   |
| <b>DESSERTS</b>      |                  |                  |                         |
| MERINGUES            | 2                | 125              | 55-60                   |
| BISCUITS             | 2                | 175              | 20-25                   |
| PASTRY               | 1                | 175              | 25-30                   |
| SPONGE CAKE          | 2                | 175              | 35-45                   |
| FRUIT PIE            | 1                | 175              | 30-35                   |



## Instructions for the user

GB-IE

### 7. CLEANING AND MAINTENANCE

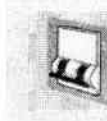

*Before performing any operations requiring access to powered parts, switch off the power supply to the machine.*

#### 7.1 Cleaning stainless steel



*To keep stainless steel in good condition it should be cleaned regularly after use. Let it cool first.*

##### 7.1.1 Ordinary Daily Cleaning

To clean and preserve the stainless steel surfaces, always use **only** specific products that do not contain abrasives or chlorine-based acids.

**How to use:** pour the product on a damp cloth and wipe the surface, rinse thoroughly and dry with a soft cloth or deerskin.

##### 7.1.2 Food stains or residues

Do not use metallic sponges or sharp scrapers: they will damage the surface.

Use normal non-abrasive products for steel, and a wooden or plastic tool if necessary.

Rinse thoroughly and dry with a soft cloth or deerskin.

Do not allow residues of sugary foods (such as jam) to set inside the oven. If left to set for too long, they might damage the enamel lining of the oven.



#### 7.2 Cleaning of the oven



*For best oven upkeep clean regularly after having allowed to cool. Take out all removable parts.*

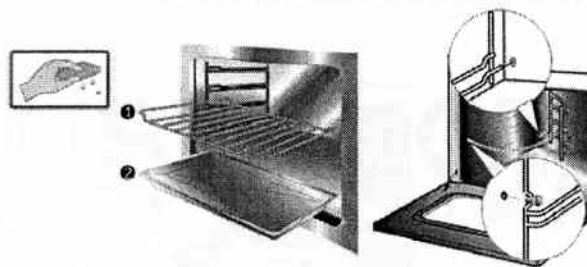

- Clean the oven grill and side guides with hot water and non-abrasive detergent. Rinse and dry.
- The oven should be operated at the maximum temperature for about 15/20 minutes after using specific products, to eliminate the residues deposited inside the oven.
- For easier cleaning, the door can be removed (see P. 8.2)

#### 7.3 Door glass

The door glass should always be kept clean. Use absorbent kitchen paper to clean. In case of tough spots, clean with a damp sponge using regular detergent.



## Instructions for the user

GB-IE

### 8. EXTRAORDINARY MAINTENANCE

The oven may require extraordinary maintenance or replacement of parts subject to wear such as seals, bulbs, and so on. The following instructions describe how to carry out these minor maintenance operations.



**Before any intervention, disconnect the power supply of the device.**

#### 8.1 Replacement of light bulb

Remove the bulb protector A by turning anticlockwise and change bulb B (in the 8-function model with front glass panel change the halogen bulb C) with a similar one. Re-fit the bulb protector A.

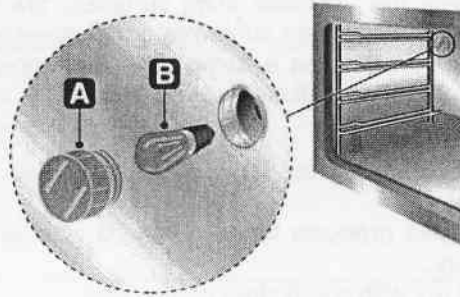

**Only use oven bulbs (T 300°C).**

#### 8.2 Removing

Hold the door on both sides with both hands near hinges A and raise levers B. Lift up the door forming an angle of about 45° and remove. To refit, slide the hinges A in the grooves, drop the door and release levers B.

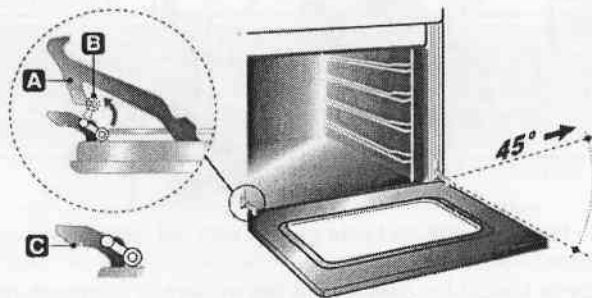

#### 8.3 Oven door seal

To permit thorough cleaning of the oven, the seal may be removed. Before removing the seal, take off the door as described above. Once the door has been taken off, lift the tabs at the corners as shown in the figure.

After cleaning, refit the seal with the longer side horizontal and insert the tabs into the appropriate holes starting from the top ones.

